



Model 35W "E" Series



Features

- Precise wraparound labeling on a wide range of cylindrical containers
- Product infeed systems provide precise product spacing and minimize change parts
- Simultaneous "dispense and wrap" method provides product stability and extra control of longer wraparound labels
- Advanced 35 Series microstepping applicators provide accurate and reliable application of a wide variety of label materials
- Centralized controls pivot for convenient operation
- Rugged heavy-duty conveyor and stainless steel base frame for years of dependable service
- Quick "no-tools" adjustments with position indication for fast, repeatable product changeover
- Wide product size range without change parts
- Easy to set up, operate and maintain

Model 35W "E" Series Wraparound Labeling System

Front View

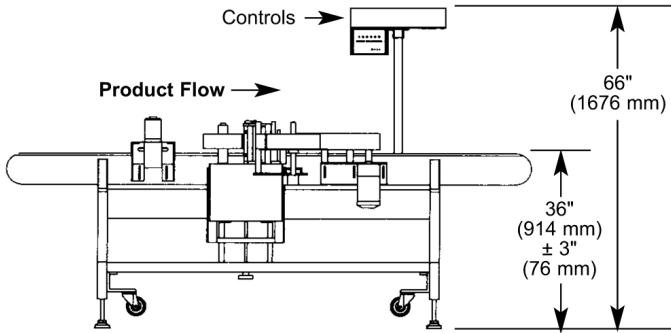

Top View

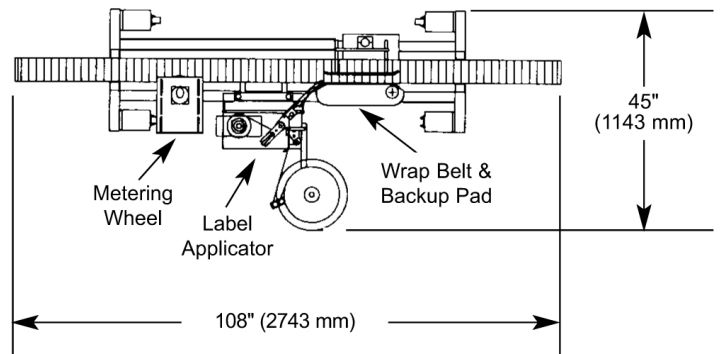

The Accraply Model 35W "E" Series is an extremely versatile labeling system designed for the application of wraparound labels on a wide range of cylindrical containers.

It comes equipped with the industry's most accurate and reliable microstepping label applicator to ensure precise and repeatable label application with years of continuous service. Its rugged construction is perfect for demanding continuous-duty operation. Quick, easy changeover capability from one product to another and proven technology make this system an exceptional value.

Options

- Hot stamp or thermal printers
- Wide web label capacity
- Extended wrap length capacity
- Clear film label sensor
- Timing screw infeed system
- Convenience alarm packages
- Conveyor extensions
- Heavy-duty casters
- Right and left handed models

Application Rate	Up to 1800" per minute
Production Rates	Up to 200 per minute depending on product and label sizes
Electrical Requirements	110 VAC, Single Phase, 60 Hz, 15 Amp Service (220 VAC required with some options)
Air Requirements	60 PSI (required with some options)
Product Conveyor	4.5" wide flush sided
Product Capacity	Maximum Diameter: 8" Maximum Height: 16" Minimum Diameter: 0.75" Minimum Height: 0.75"
Label Capacity	Maximum Length: 12" Maximum Height: 6" Minimum Length: 2" Minimum Height: 0.5"

** All specification and tooling requirements are subject to Accraply evaluation of all label and product samples. Specifications shown reflect standard machine capabilities. Accraply can also meet other specification requirements. Please call for details.*

Accraply

Trine

Stanford

Graham

Sleevit

Harland

BW Packaging Solutions consist of Accraply, BW Container Systems, Design Group, Paper Converting Machine Company, Pneumatic Scale Angelus, Thiele Technologies and Synerlink. Through their diverse capabilities, these companies can collectively provide everything from a single piece of equipment to fully integrated, tailor-made packaging line solutions for a wide range of industries, including: food and beverage, personal care, container manufacturing, pharmaceutical and medical devices, household products, paper products and textiles, industrial and automotive, and converting, printing and publishing.

BWPackagingSolutions.com

barry wehmiller
bw
betterworld